

NPS Meeting 05 Oct 2017

(Hamlet Mkrtyan)

1. New PMTs have been delivered with slightly different sockets



- Machining needed to bring sockets to diameter < 20 mm
- Ask Hamamatsu for different version of socket (acceptable for us)

Note, 100 new PMT R4125 from “clean room” moved to Hall D (Fernando will start assembling and testing HV dividers). There is a plan (idea) to study PMTs relative QE, gain, and may be linearity
Have one working new divider and new PMT for Carlos, need to organize shipping.

2. Primex PbWO module initial design

Have copy drawings of Primex Lead-Glass and PbWO blocks (Thanks Ashot and Alexander)

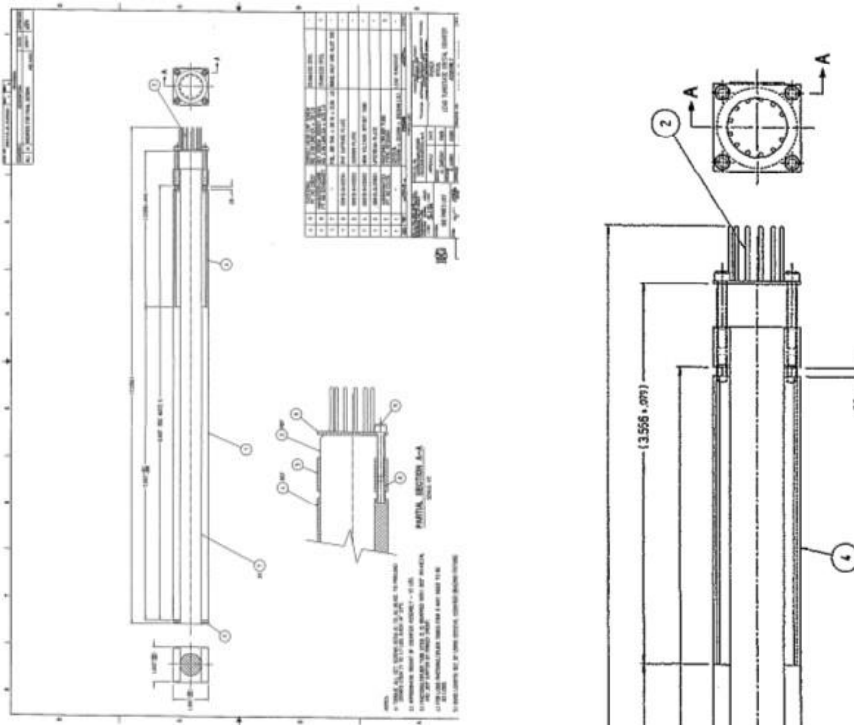

4. Proposed assembly of NPS PbWO modules

Full assembled block

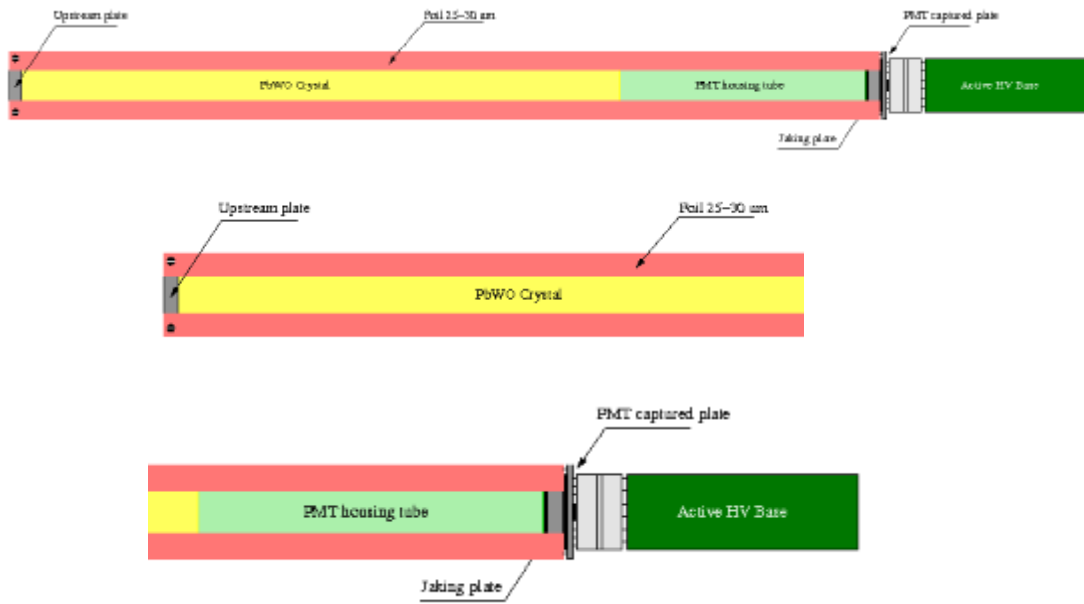

PMT, socket, divider and their assembly

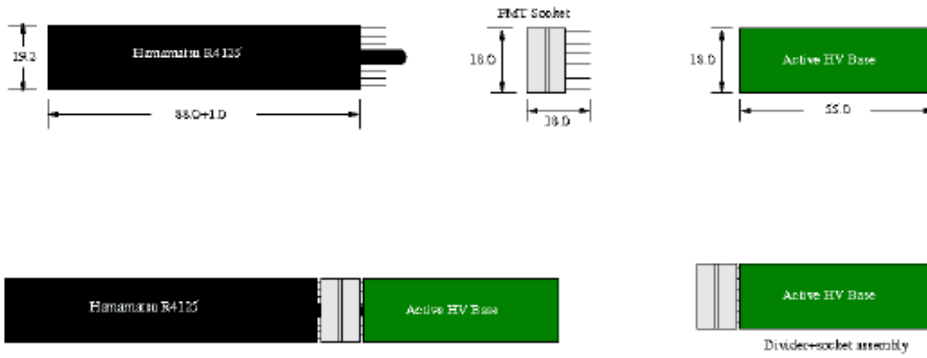

Details of block assembly

