

**Abstract** - A new photomultiplier tube active base is designed and tested. The base combines active voltage division circuit and fast amplifier, powered by the current flowing through voltage divider. This base is developed to upgrade older photomultiplier bases of Jefferson Lab lead-tungsten calorimeter (about ~1200 crystals of PbWO<sub>4</sub> from the PrimEx experimental setup). This is need in order to extend detectors rate capability to meet requirements of new Hall C proposal PR12-11-102 of measurements of the L/T separated cross sections and their ratio  $R = \sigma_L/\sigma_T$  in neutral-pion  $p(e,e'\pi^0)p$  deep exclusive and  $p(e,e'\pi^0)X$  semi-inclusive scattering regions. New active base is direct replacement of older passive base circuit without adding of additional power or signal lines. In addition, it extends detectors rate capability with factor over 20. Moreover, transistorized voltage divider improves detector's amplitude resolution due to reduction of photomultiplier gain dependence from tube anode current. The PMT active base is the invention disclosed in V. Popov's U.S. Patent No. 6,791,269, which successfully works over ten years in several Jefferson Lab Cherenkov detectors. The following design is a new revised and improved electronic circuit with better gain stability and linearity in challenge to meet requirements of new Hall C experimental setup. New active base performance was tested using fast LED light source and Pr:LuAG scintillator and gamma sources. Electronics radiation hardness was tested on JLab accelerator. Results of testing R4125 Hamamatsu photomultiplier tube in new active base are presented.

## I. INTRODUCTION

To implement JLab proposal PR12-11-102 [5] of measurements of the L/T separated cross sections and their ratio  $R = \sigma_L/\sigma_T$  in neutral-pion  $p(e,e'\pi^0)p$  deep exclusive and  $p(e,e'\pi^0)X$  semi-inclusive scattering regions the lead-tungstate calorimeter (about ~1200 crystals of PbWO<sub>4</sub> from the PrimEx experimental setup will be used [2]). The calorimeter is needed for neutral pion detection by measuring of its  $\gamma\gamma$  decay products in a dedicated neutral-pion detector. The radiation background and detectors' count rate simulation predicts 10-20 higher rates comparing to PrimEx experiment. PrimEx lead tangstate calorimeter is assembled with R4125 Hamamatsu photomultiplier tubes equipped with passive resistors chain dividers, which are not capable to handle new radiation flux. To increase detectors' rate capability, new active photomultiplier base is developed and tested. This base is comprised of amplifier, entirely powered by the current flowing through the base voltage divider [3], and replaces the older passive base circuit without adding any additional power or signal lines. The active base electronic circuit supports the detector operation at lower high voltage bias, at the same time maintaining high output amplitude. In addition, active high voltage division circuit substantially reduces photomultiplier gain dependence from tube anode current and count rate.

## II. ACTIVE BASE CIRCUIT OVERVIEW

R4125 is a round shape, 19mm in diameter Hamamatsu photomultiplier tube. With gain about  $8.7E+5$  at 1.5kV max. anode voltage, and rise time 2.5ns. New photomultiplier base is designed with the same as PrimEx experiment base voltage distribution ratio, but with lower total impedance and two transistors added to dynode 9 and 10 connection nodes. Fig. 1 shows a simplified circuit diagram of new base.

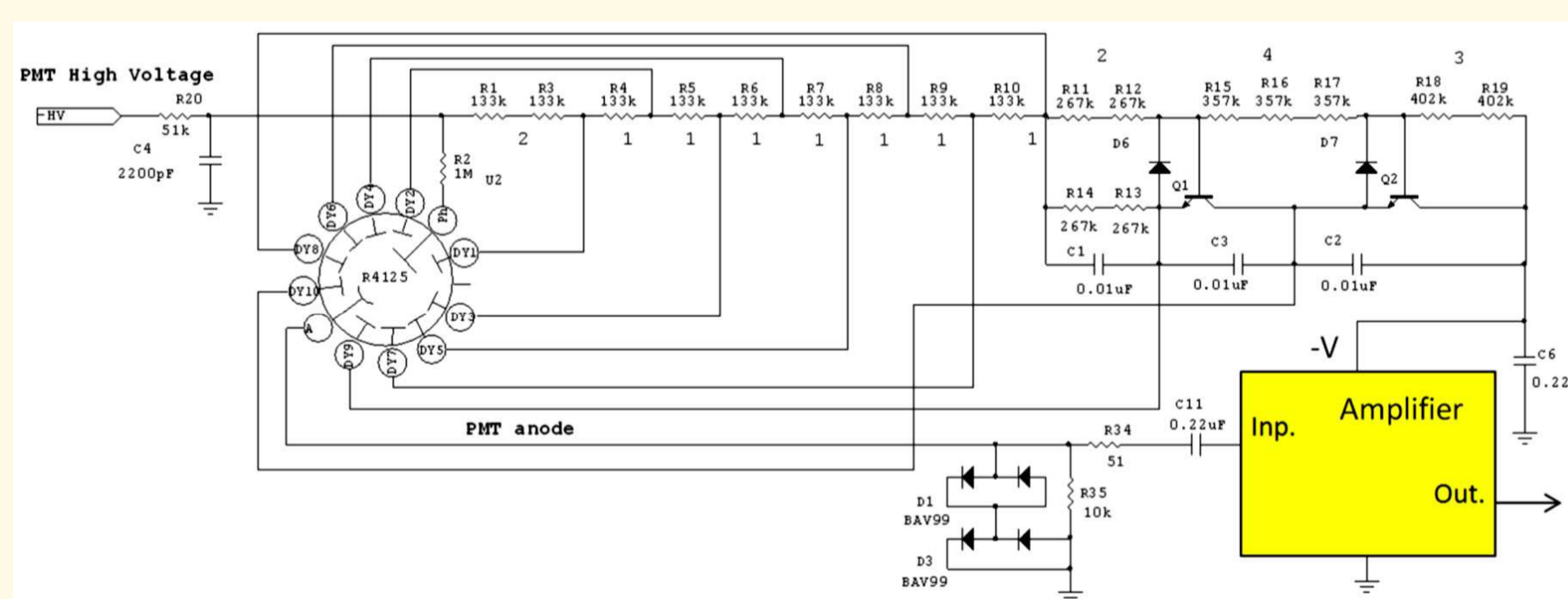

Fig. 1 shows a simplified circuit diagram of new base. The active base circuit is powered from divider current.

Fig. 1 Simplified circuit diagram of new photomultiplier base which comprise an active base dynodes biasing circuit and amplifier powered from divider current.

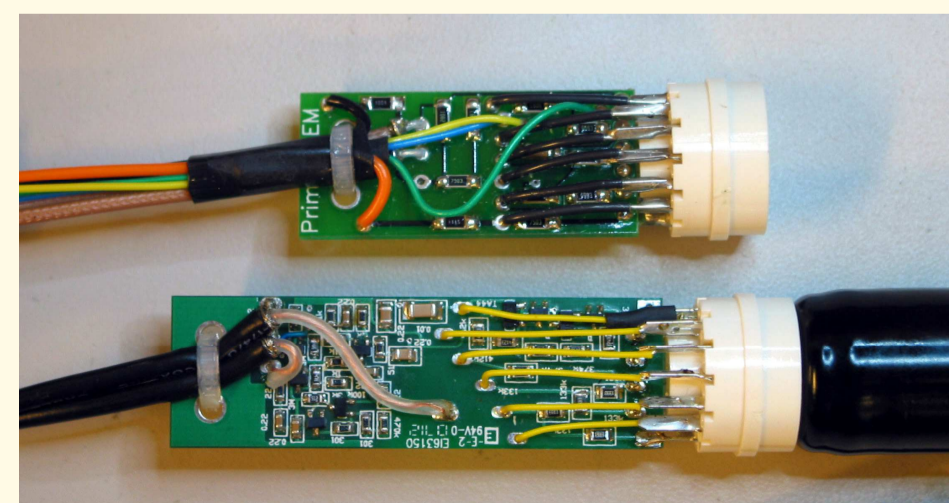

Fig. 2 Photograph of passive and active bases for R4125 phototube

Because of progressive voltage division function of used divider, two transistors active circuit is sufficient for tube gain stabilization. Divider current is changed from 170mA at 1.5kV of passive PrimEx divider to 470mA at 1.1kV of new divider to improve rate capability and for better operation of inserted amplifier circuit.

Fig. 2 show photograph of both bases used in this study. Upper photo is a passive divider base and lower is a new active tube base. Both of them allow a scalable photomultiplier counter layout, and operate from a single high voltage source.

Amplifier circuit is designed on discrete high frequency transistors and it is similar to previously published at [2] circuit. Amplifier gain is about 10 and maximum linear pulse output amplitude is about 5V on 50Ω load. This amplifier serve to compensate gain reduction at lower PMT operating voltage and allowed system operation with 10 times lower anode current without loss of overall gain and output amplitude see. [1,2].

## III. TEST OF ACTIVE BASE

Test measurements of new active base performance and comparison with passive circuit from PrimEx experiment were performed using Agilent 54832D MSO digital oscilloscope, Agilent 33220A functional generator connected to LED light source trough designed for this test amplifier-shaper, and with Pr:LuAG fast bright scintillator radiated from different gamma sources [4]. This scintillator has ~22000ph/MeV light output and it is used to simulate hundreds MeV equivalent light pulse of PbWO<sub>4</sub> scintillator.

### A. Test with scintillator light source.

5mm<sup>3</sup> cube shape sample attached to R4125 photomultiplier tube was used to estimate detector energy scale. Fig. 3 shows a waveforms of pulses obtained with passive and active base.

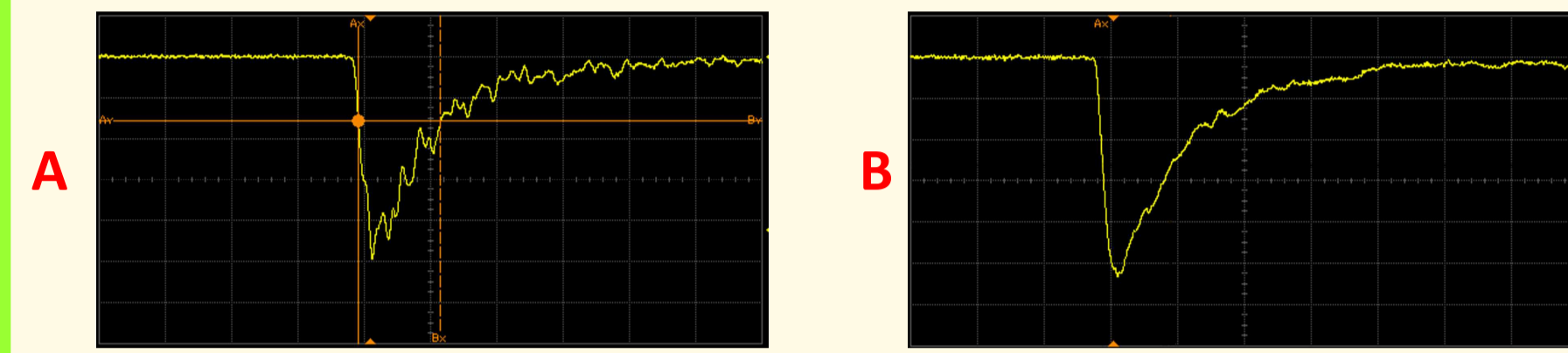

Fig. 4 A-output pulse waveform from passive base with PMT and Pr:LuAG scintillator, 20ns/div scale FWHM=20ns, fall time=2.4ns; B-output pulse waveform from passive base with PMT and Pr:LuAG scintillator, 20ns/div scale FWHM=24ns, fall time=3.2ns;

Both bases were evaluated with scintillator and gamma sources to equalize both examine systems gain and linearity. Agilent 54832D oscilloscope was used to plot pulse height distributions (PHD) with different radiation sources. Fig. 5 shows a sample of <sup>22</sup>Na source PHD obtained with active base at 1.09kV bias voltage. Passive base show almost identical histogram at 1.5kV applied to PMT.

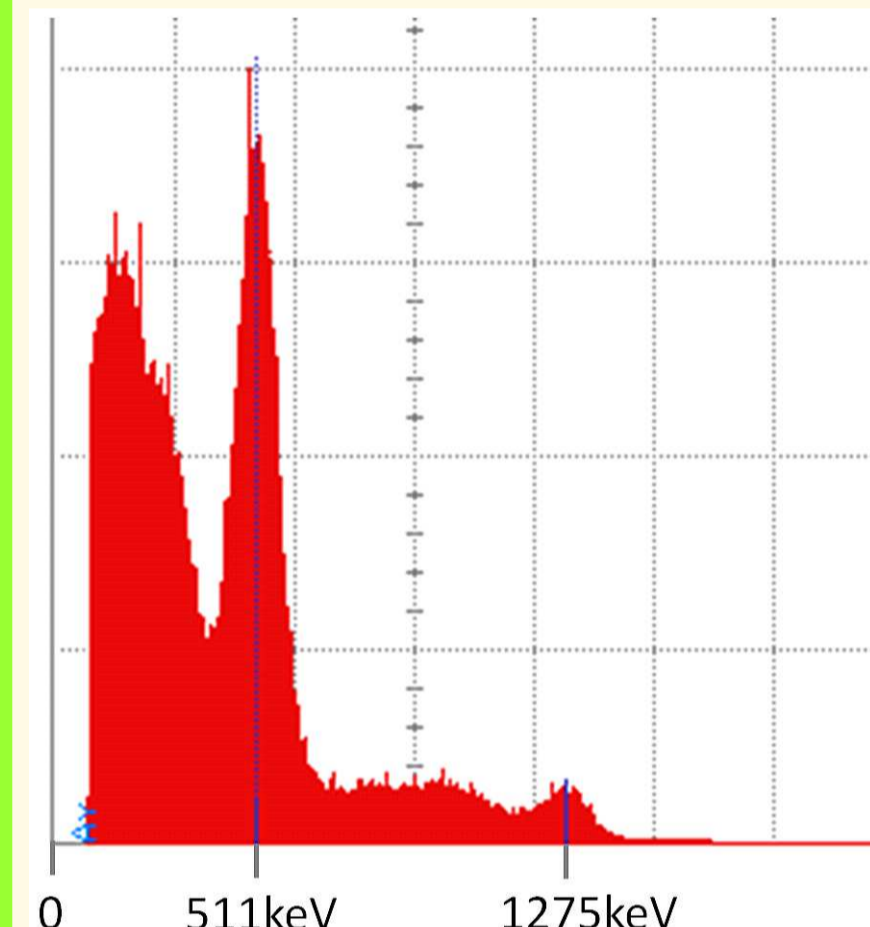

Fig. 5 <sup>22</sup>Na gammas energy spectrum (PHD) histogram recorded with Agilent 54832D oscilloscope from active base with PMT, Pr:LuAG scintillator. FWHM=20% for 511keV peak.

This test shows that we have a very similar behavior of both bases, but new active base could operate at much lower high voltage and anode current without reduction of output amplitude and linearity.

### B. Test with LED light source

Active and passive PMT biasing circuits were tested and characterized for linearity at different count rates using blue LED source controlled by pulse generator. Two set of results were obtained, with LED pulse width around 15ns and 6ns. Shorter LED pulse were produced with designed active circuit made of 74AC TTL family gates with LED in SMD 0805 case mounted close to logic chip and with RC circuit used to reproduce near identical to real PbWO<sub>4</sub> scintillator crystal waveform. Fig. 5 shows pulses captured from scintillator and adjusted LED source with two examined PMT bases.

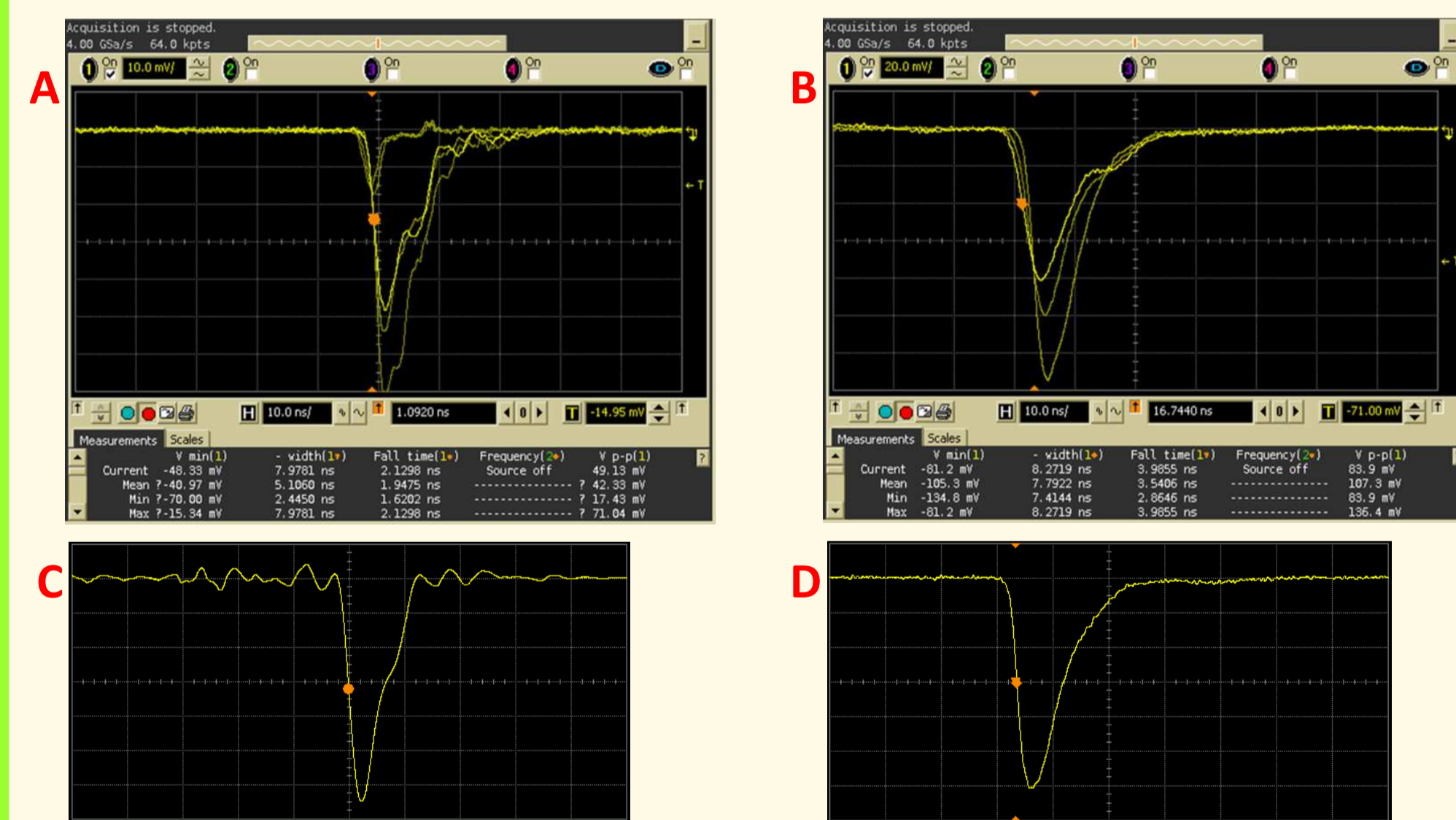

Fig. 5 A and B are waveforms of PbWO<sub>4</sub> scintillator, A-with passive base, B-with active base; C and D are similar waveforms but generated with LED light source. All four pictures are presented at 10ns/div scale: A-FWHM=5.1ns,  $t_f$ =2ns; B-FWHM=7.8ns,  $t_f$ =3.5ns; C-FWHM=6.5ns,  $t_f$ =2.6ns; D-FWHM=8.1ns,  $t_f$ =3.2ns. X-scale is 10ns/div

Rate capability of both bases was studied with PbWO<sub>4</sub> similar LED light source. During this test an average amplitude of output pulse was measured using oscilloscope. Fig. 6 shows a few plots of PMT and base assembly gain dependence from light pulse rate. When both bases are operating with the same rate and average output pulse amplitude, new active base has factor 10 lower anode current with linear operation rate range over factor 50 higher.

Active base equivalent output integral current depends from divider circuit drain current, linear region is about 85% of divider current. For designed circuit linear operation maximum, of equivalent integrated output current, is about 400mA.

## References

- [1] V. Popov, S. Majewski, B. Wojtkowski, D. Guerin, "A simple method to increase effective PMT gain by amplifier circuit powered from voltage divider", Conference Proceedings of 2001 IEEE NSS/MIC, San Diego, California, USA, 4-10 November 2001.
- [2] Vladimir Popov, "Design and study of photomultiplier pulse-shaping amplifier powered by the current flowing through a voltage divider", Nuclear Instruments and Methods in Physics Research A 505 (2003) 316-319
- [3] Talk on the CALOR06 Conference, Chicago Journal reference: AIP Conf.Proc.867:51-58,2006 DOI: [10.1063/1.2396938](https://doi.org/10.1063/1.2396938), Cite as: [arXiv:physics/0609201v1](https://arxiv.org/abs/physics/0609201v1) [physics.ins-det], M. Ku bantsev, I. Larin, A. Gasparyan, for the PrimEx Collaboration
- [4] Furukawa Co., Ltd., Japan, <http://www.furukawakk.co.jp/pdf/other/hikaku.pdf>
- [5] [www.jlab.org/exp-prog/proposals/11/PR12-11-102.pdf](http://www.jlab.org/exp-prog/proposals/11/PR12-11-102.pdf)
- [6] R. Asaturyan et al., The aerogel threshold Cherenkov detector for the High Momentum Spectrometer in Hall C at Jefferson Lab, NIM in Phy. Res. A548 (2005) 365-374

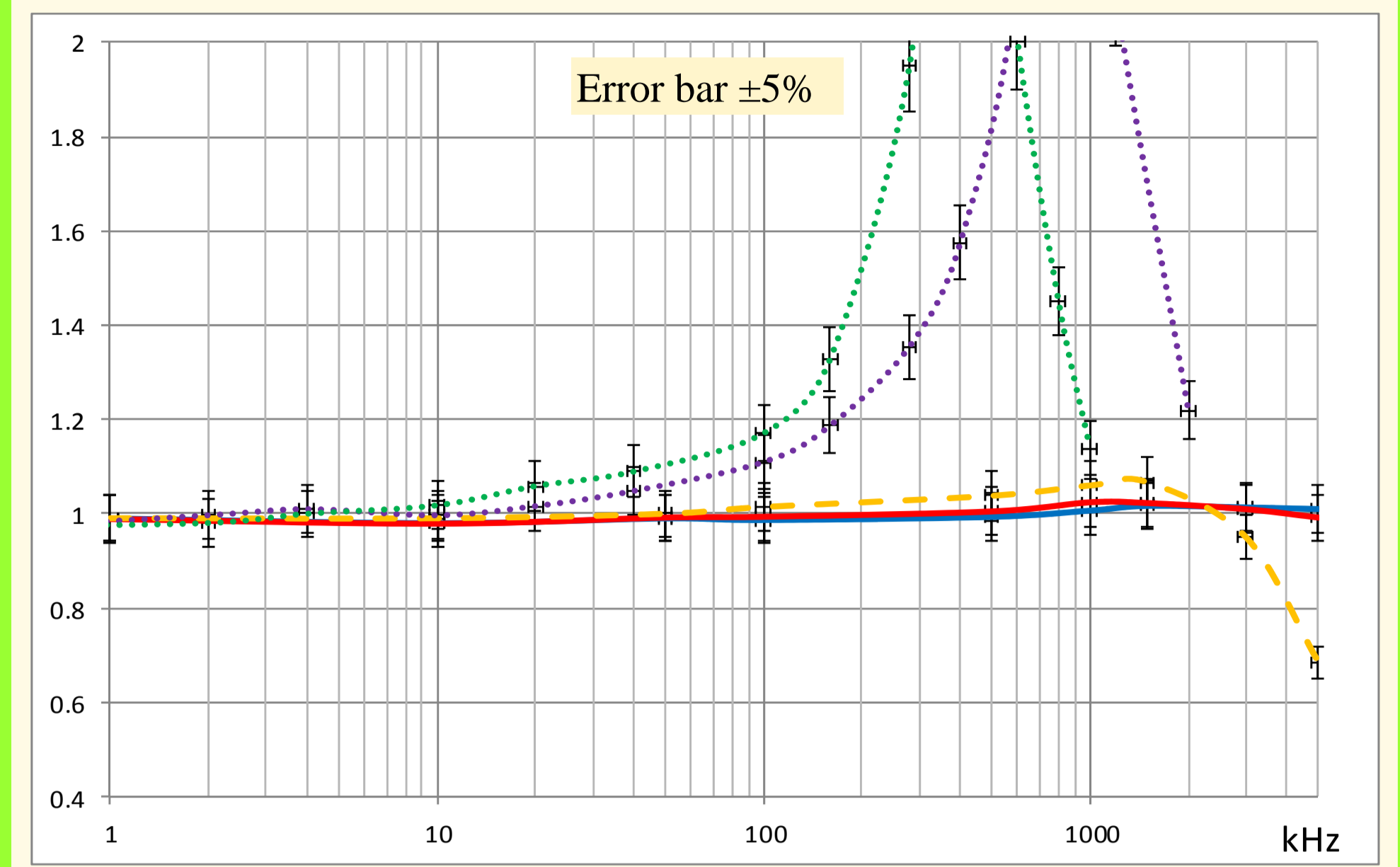
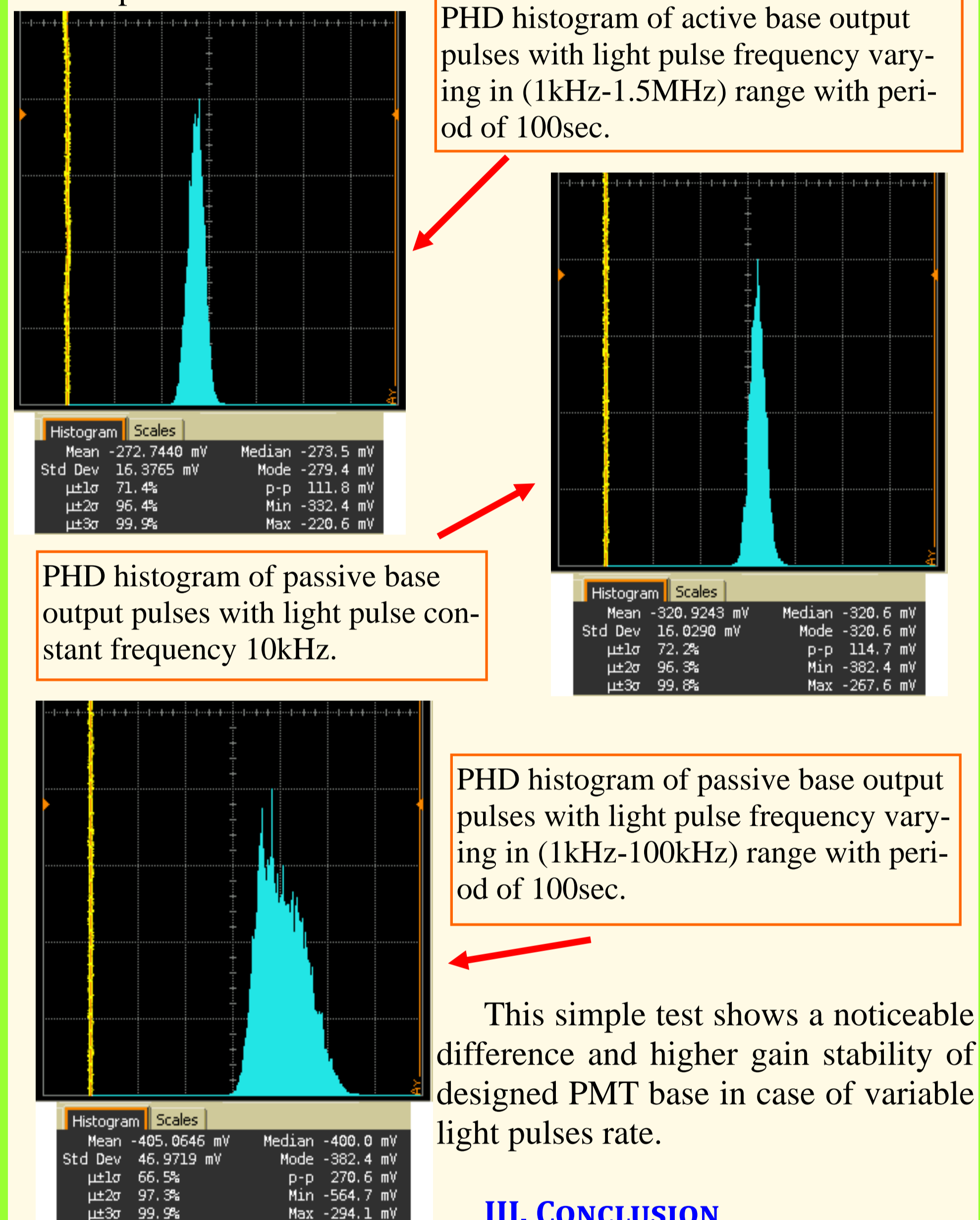

Fig. 6 Normalized gain as a function of pulse repetition rate of PbWO<sub>4</sub> scintillator similar LED light source.

Active base, initial amplitude: — 300mV; — 600mV; — 1000mV  
Passive base, initial amplitude: ..... 300mV; ..... 600mV

### C. Two bases test with sweep generator.

Agilent 33220A functional generator operating in linearly varying frequency mode was connected to LED light source. Results of this test are presented below.



## III. CONCLUSION

New type of active photomultiplier base for upgrade of JLab Hall C PbWO<sub>4</sub> scintillator crystals calorimeter is designed and tested to fit all requirement of new proposed experiment. Active base circuit does not need additional power lines and could be installed as a direct replacement of older bases. Base shows important for calorimeter application gain stability at increased event rate frequency and frequency variation. Radiation hardness of designed circuit was tested during operation of JLab accelerator. After receiving of 150krad dose no changes were observed.

Developed active base circuit contains 5 silicon bipolar discrete transistors (three in amplifier circuit and two in HV divider) and may be easy assembled on a small board (see Fig. 2). Estimated cost is about ~\$5 in case of 1000+ boards production.

Active base with amplifier powered from current flowing through high voltage divider was invented in JLab, and it is tested over 10 years in JLab, mainly as a part of Cherenkov detector with Photonis XP4572B phototube [2,6], which are rarely working at high rate high anode current mode. New active base circuit with improved gain stability has a wider field of application where high gain and gain stability are important. It may be applied to many aged photomultipliers for loss of gain compensation, or in new systems, where this base makes possible use of less expensive low gain tubes. In all applications the developed circuit will extend photomultiplier tube life, it does not need additional power line, and reduce power for PMT operation at desired rate.